

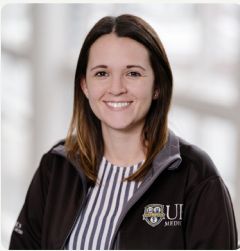

Enable more sequencing for more labs

Flexibility, faster turnaround times, lower costs: the Genomics Research Center (GRC) at Rochester University enables more scientists to do more with their samples by leveraging high-density sequencing on the Illumina NovaSeq™ X Series and 25B flow cell.



“ This 25B flow cell is a great example of the diverse library types we are able to sequence in an efficient way. We partner with external institutions and collaborators to ensure our flow cells are filled quickly, which helps with turnaround time and, importantly, to lower costs overall.”

Elizabeth Pritchett, PhD
Rochester Genomics Center, Operations Director

8 library types, 6 labs, 1 flow cell

NovaSeq X Series and the 25B flow cell allow Dr. Pritchett and her team to increase cost-efficiency, improve sample flexibility, and maintain superior quality, which increases sequencing accessibility for scientists.*

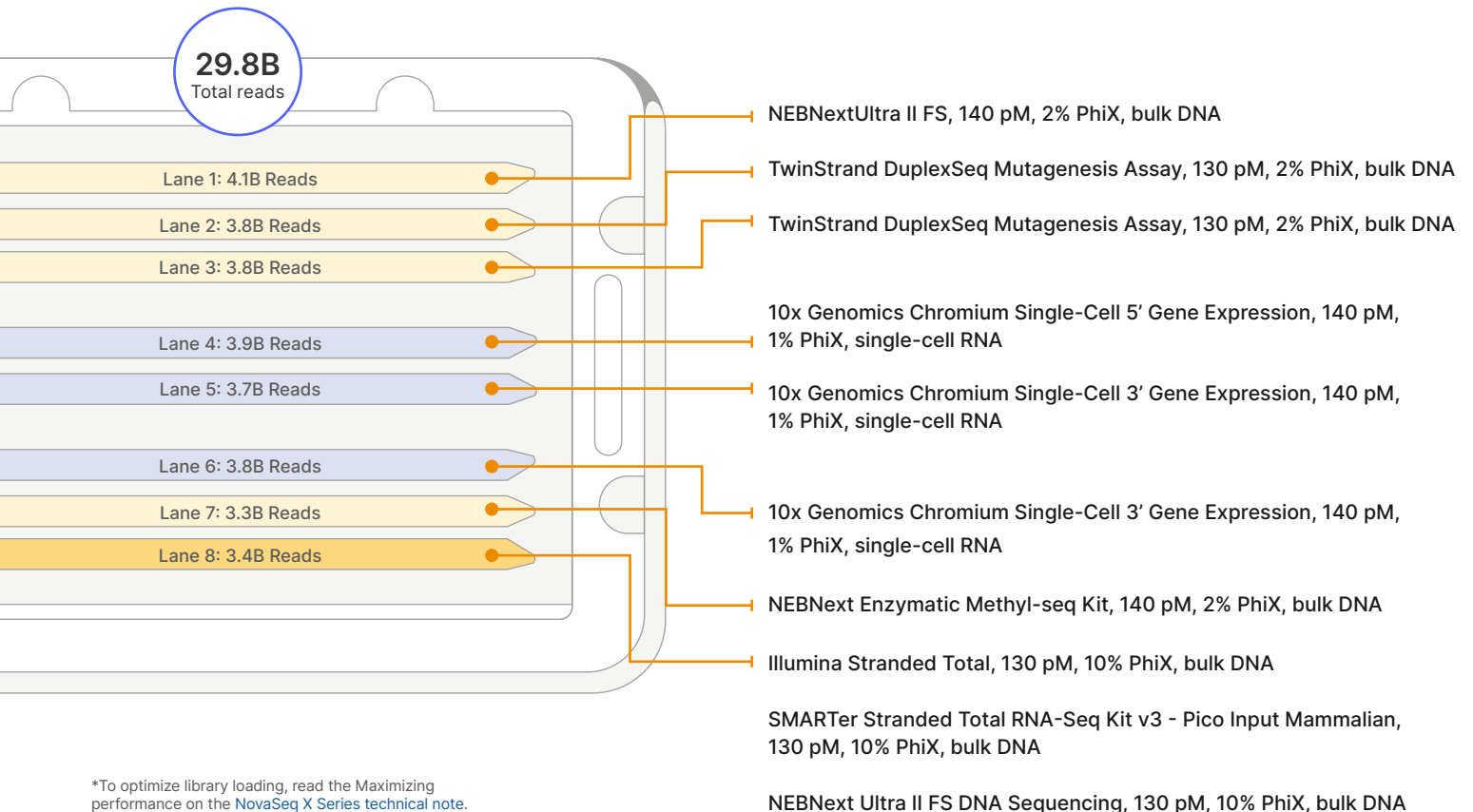

*To optimize library loading, read the Maximizing performance on the NovaSeq X Series technical note.

Robust data yield and dependable quality for diverse libraries

When you work with the right partner, you can achieve optimal results for deeper sequencing with minimal sample input. Here's an in-depth look at the results GRC achieved with sample multiplexing on a 25B flow cell with the NovaSeq X Series.†

Achieve consistent performance across all lanes

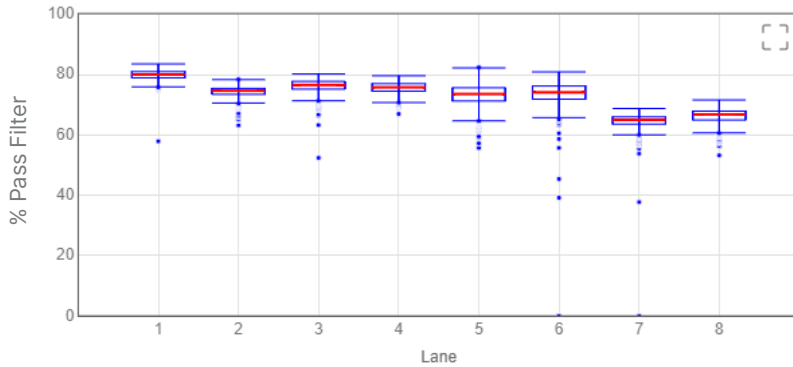

“ For this particular run, we were able to leverage the flexibility of the lanes on the NovaSeq X Series 25B flow cell to accommodate external institution samples, while also ensuring the projects of our internal users were moved through quickly.”

Elizabeth Pritchett, PhD
Rochester Genomics Center,
Operations Director

Quality and accuracy exceed performance specifications

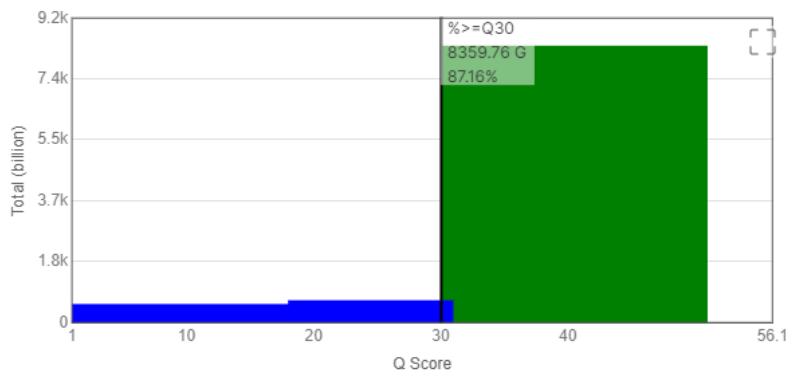

†To ensure accurate results for your samples, further optimization is recommended. Contact the Illumina Tech Support team for assistance.

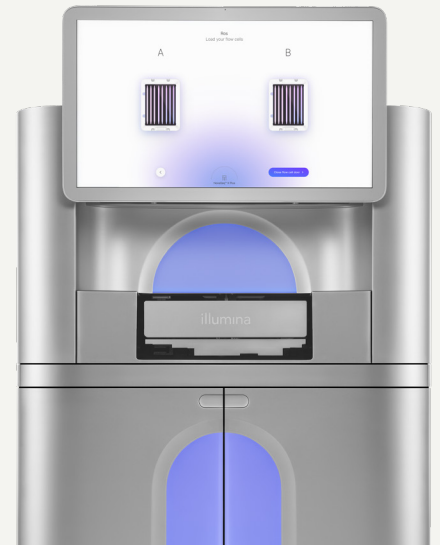

Increase access to sequencing today

With the NovaSeq X Series, you can enable more science for more labs with flexible sequencing at a historically accessible cost per lane.



Discover how to optimize
your NovaSeq X Series run